

# A Real-time Simulation Platform for Maximum Power Point Tracking Algorithm Study in Solar Photovoltaic System

Meng Chung Tiong, Hamdan Daniyal\*, Mohd Herwan Sulaiman, Mohd Shafie Bakar and Suliana Ab Ghani

Faculty of Electrical and Electronics Engineering, Universiti Malaysia Pahang, 26600 Pekan, Pahang, Malaysia

\*Corresponding author: hamdan@ump.edu.my

Received 18 April 2019, Revised 13 May 2019, Accepted 15 May 2019.

**Abstract:** This paper presents the application of controller hardware-in-the-loop (C-HIL) for real-time study of maximum power point tracking (MPPT) algorithm in solar photovoltaic (PV) system. The testing platform in this study which consist of three series connected PV modules together with a DC/DC boost converter were modelled and implemented using Typhoon HIL-402. For the MPPT controller, a conventional perturb and observe (P&O) and a well-established particle swarm optimization (PSO) based MPPT algorithm are developed and implemented in a digital signal processor. The performance of both algorithms were examined under real-time working condition with 10 different partial shaded test cases. From the study, the P&O shows a faster convergence speed which it can track for maximum power point rapidly up to 0.5070 s compared to the fastest tracking of PSO at 1.3598 s. However, PSO shows a greater capability in tracking for true maximum power point under partial shaded conditions with average output efficiency up to 99.92% compared to P&O which is only 76.76%.

**Keywords:** DSP; HIL; Maximum power point tracking; Photovoltaic; Real-time simulation.

## 1. INTRODUCTION

Solar photovoltaic (PV) has emerged as one of the most favorable renewable energy source in power generation. This is due to the abundance of solar irradiance, easy implementation and environmental friendly which it does not produce pollutants during the operation. In term of economical aspect, it is always the challenge to ensure the installed photovoltaic system to perform at its maximum available capacity in order to maximize the return of investment. One of the most economical and efficient way is by employing maximum power point tracking (MPPT) to the PV system to adjust the optimal operating point for the PV system to generate maximum power.

The maximum power point is where the matching of operating point between PV array and power converter to maximize the power transfer from the PV array to the power converter [1]. Due to the nonlinear characteristics of the PV cells and the varying working conditions, the maximum power operating point of PV module is difficult to be predicted. Furthermore, the problem become more challenging when the entire PV array does not receive equal amount of solar irradiance, which results in a condition known as partial shading. Under partially shaded conditions, the power-voltage (P-V) characteristic curve of the PV array exhibits in several peaks, with only one global peak (true peak). This often causes the conventional MPPT algorithm to trap at the local peaks, which results in power loss.

Over the years, there were plenty of MPPT algorithms being developed, which it can be seen from the growth in number of the related papers [2]-[5]. Recent years, with the availability of vast and low cost microcontrollers, the soft computing (SC)-based MPPT methods are attracting considerable interest among researchers [6]-[8]. The flexibility of the SC methods allows the development of robust MPPT algorithms which can solve more complex problems like the multiple peaks situation during partial shading conditions [9].

In the process of MPPT controller development until the actual implementation, the controller often undergoes series of testing and verification. In early stage of development, the plant model and controller were often developed and examined using software simulation technique through the process of Model-in-the-loop (MIL) and Software-in-the-loop (SIL). At MIL process, the model developed is examined so that it is implementable with the designed algorithm. While at SIL stage, the software code generated by the algorithm was examined before it was implemented in the final hardware [10]. It is very important to note that during the MIL and SIL stages of development, the model plant and controller were not examined under real-time condition [11].

In order to further examine the designed system or algorithm under real-time condition, it is very common to implement the design into the actual hardware and perform series of testing. With the emerging of hardware-in-the-loop (HIL) platform, it makes the possible for a newly developed system to be evaluated under real-time condition without the need of constructing

the actual system. This enables the prototype to be examined virtually under wide range of parameters safely and economically. In typical application, the actual hardware involved in HIL simulation consist of only controllers where the power devices were not physically constructed. Such simulation is known as a controller hardware-in-the-loop (C-HIL) simulation [12]. The power components such as power grids, power electronic converters, rotating machines and sensors were virtually simulated in the simulator. The real-time output signal, together with the controller under test forms a closed loop environment. The signal exchange between the simulator and controller were carried out at low voltage and power level. This brought to the strength of the C-HIL simulation where it does not cause hazards as well as damaging the test facilities, at the same time, it reduces the time consuming process of physical hardware construction.

In the process of development and implementation of different algorithms in solar MPPT controllers, it is crucial to examine the capability as well as the performance of both the algorithms and controllers under real-time conditions. Different with the software simulation, the execution of the algorithms under real-time conditions were highly depends on the processing power of the controller. In this study, the performance of two MPPT algorithms, Perturb & Observe (P&O) and Particle Swarm Optimization (PSO) were examined under real-time operating condition using C-HIL simulation method. The performance of the MPPT algorithms were evaluated in term of tracking output efficiency and its convergence time under 10 different partial shaded test conditions.

## 2. SYSTEM MODELLING AND DEVELOPMENT

### 2.1 System Modelling in MATLAB/Simulink

In order to study the real-time performance of the MPPT algorithms, the proposed system was developed and simulated in MATLAB Simulink in early stage. The system consists of a plant which is made up by a string of PV module, a DC/DC boost converter and loads, while the controller part of the system were made up by a MPPT controller where different MPPT algorithms in study can be implemented. In software simulation platform, the power circuit (plant) and control circuit were constructed in MATLAB Simulink as shown in Figure 1. The irradiance and temperature of different PV modules can be set according to the study case.

In PV cell modelling, the characteristic of a PV cell can be represented by using equivalent electric circuit which consist of a current source, a diode, a shunt resistance and a series resistance [13]. With the consideration of the effect of shunt resistance is relative small in a single module, the shunt resistance was removed from this simulation model [14]. In order to increase the accuracy of the model, the effect of temperature on the short circuit current ( $I_{sc}$ ) and the reverse saturation current of the diode ( $I_o$ ) were included. The current-voltage ( $I$ - $V$ ) relationship of the PV cell can be described as:

$$I = I_{sc} - I_o \left( \exp \frac{q(V + IR_s)}{mkT_c} - 1 \right) \quad (1)$$

where  $I$  is the cell current,  $I_o$  is the diode reverse saturation current,  $q$  is the electron charge,  $R_s$  is the series resistance of the PV cell,  $k$  is the Boltzmann constant,  $m$  is the diode ideality factor and  $T_c$  is the junction temperature measured in Kelvin.

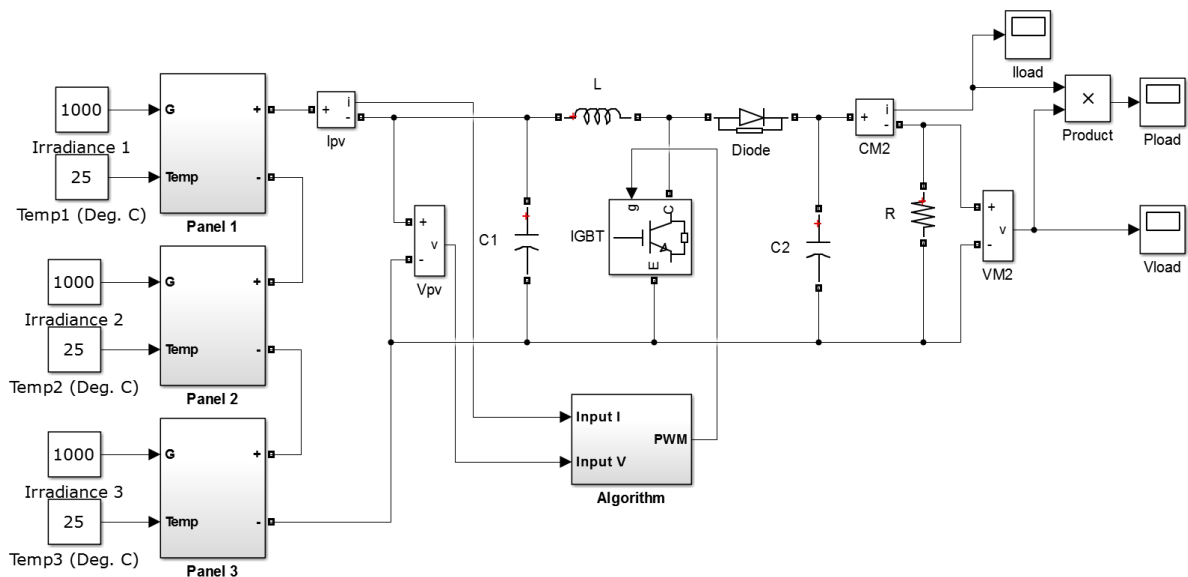

Figure 1. Proposed system in study in MATLAB Simulink

## 2.2 System Modelling in Typhoon HIL-402

After the developed model was simulated and examined in software simulation platform, the exact system was implemented in real-time simulation platform by using a HIL device and a digital signal processor (DSP). The power circuit (plant) were modelled and embedded in Typhoon HIL-402 which act as the hardware emulator for the plant in study. In Typhoon HIL-402, a field-programmable gate array (FPGA) was tailored in specific configuration with different solver computational elements by the manufacturer. This enables the HIL to perform electrical domain modelling for various complex electrical circuit under real-time condition.

In this study, the main computational elements used in the HIL were standard processing core (SPC) and look-up-table (LUT) where the SPC were in charge of simulation the electrical circuit which consist of passive elements and power converter, whereas LUT was used to simulate the behaviour of the PV module. In order for the PV model in the HIL to react effectively under different partial shaded conditions, the  $I$ - $V$  characteristic curve for the PV string under such conditions were predetermined and generated through the PV waveform generator in the Typhoon HIL software.

To complete a closed-loop C-HIL simulation platform for MPPT study, the control section of the system was implemented using a Texas Instrument F28335 DSP control card. The MPPT algorithms in study which were modelled in software simulation platform were transferred into the DSP controller with all the parameters remain unchanged. The output signal (voltage and current) from the HIL were fed into the DSP controller as low voltage signal where the algorithm in the DSP will compute and send the switching signal to the HIL device. In order to ensure the power converter has attained its steady state during the sample is taken, the sampling interval for PSO was chosen at 0.05 s [15]. The graphical description of the C-HIL simulation platform in this study is shown in Figure 2 while the experimental setup of the study is shown in Figure 3.

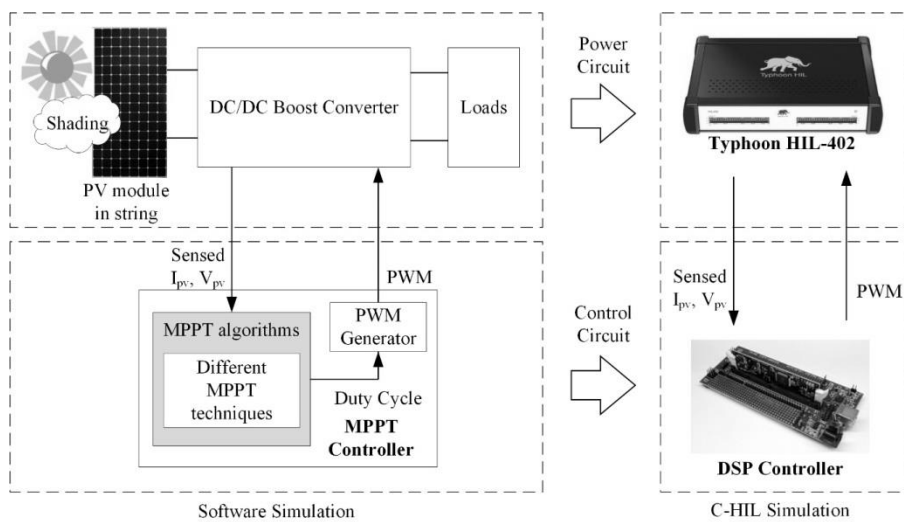

Figure 2. Graphical description of the proposed C-HIL simulation study platform

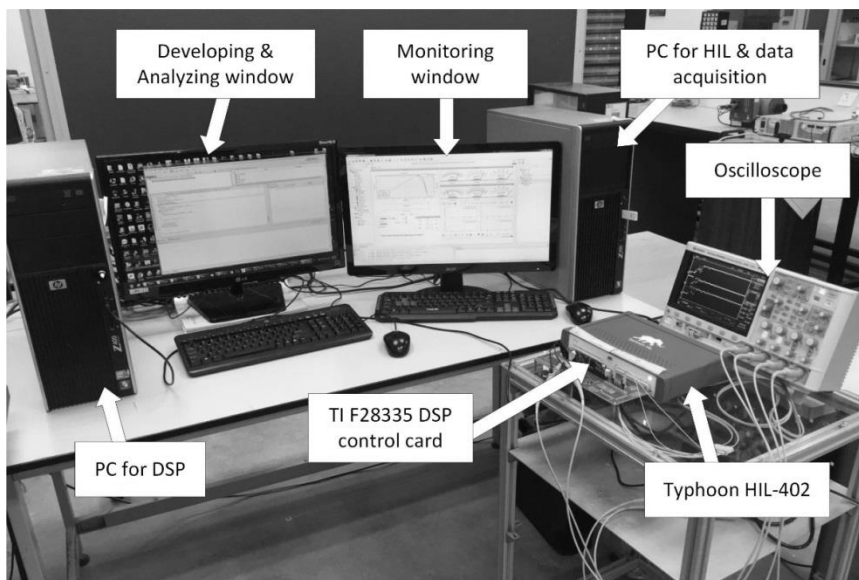

Figure 3. Experimental setup of real-time C-HIL simulation study platform

### 2.3 MPPT Controller

For MPPT controller, the algorithms implemented in this study were conventional P&O method and PSO. P&O is one of the most popular choice of MPPT method among researchers [16], [17]. It is a simple hill climbing MPPT method which the algorithm compares the existing output power with that of the previous perturbation cycle. From the sensing of voltage and current from the PV output, the power generated by the PV is calculated and the perturbation direction is determined. If the given perturbation leads to a higher output power from the PV, the subsequent perturbation will be carried in the same direction, otherwise, it will perturb in opposite direction. The P&O algorithm implementation is shown in Figure 4.

For PSO, it is a soft computing based random population search algorithm. It is modelled after the social behavior of animals such as bird flocks and fish schooling [18]. The search begins by a swarm of randomly initialized particles in the search space, where each individual represents a candidate solution. Through the emulation of the success of the neighboring particles and its own achieved success, the movement and new position of the particles were updated accordingly in each iteration. Eventually, the particles will converge until the termination criterion is satisfied. The position of the PSO particles were updated by using Equation (2), where  $x$  is the position of the particles and  $\phi$  represents the velocity component.

$$x_i^{k+1} = x_i^k + \phi_i^{k+1} \quad (2)$$

The velocity component can be obtained as:

$$\phi_i^{k+1} = \omega\phi_i^k + c_1r_1\{P_{besti} - x_i^k\} + c_2r_2\{G_{besti} - x_i^k\} \quad (3)$$

where  $\omega$  is the inertia weight factor,  $c_1$  and  $c_2$  are the learning coefficients,  $r_1$  and  $r_2$  are the random variable generated while  $P_{best}$  is the best position of the particular individual particle and  $G_{best}$  is the best position recorded by the entire population of the search particles. In this study, the parameters used by PSO were adapted from the study done in [19], [20] as: number of particles,  $N_p = 3$ ,  $c_1 = 1.2$ ,  $c_2 = 1.6$  and  $\omega = 0.4$ . These parameters were also implemented in similar studies carried out in [15], [21]. During the MPPT application, the positions of the search particles were represented by the different operating point of the PV system while the fitness of the particles were evaluated by the output power generated from the system. The output power from the PV system was unknown during the tracking process and it is always replaced by the next higher value that the search particles achieved. The objective of the algorithm is to search for the operating point that is able to deliver maximum power from the system.

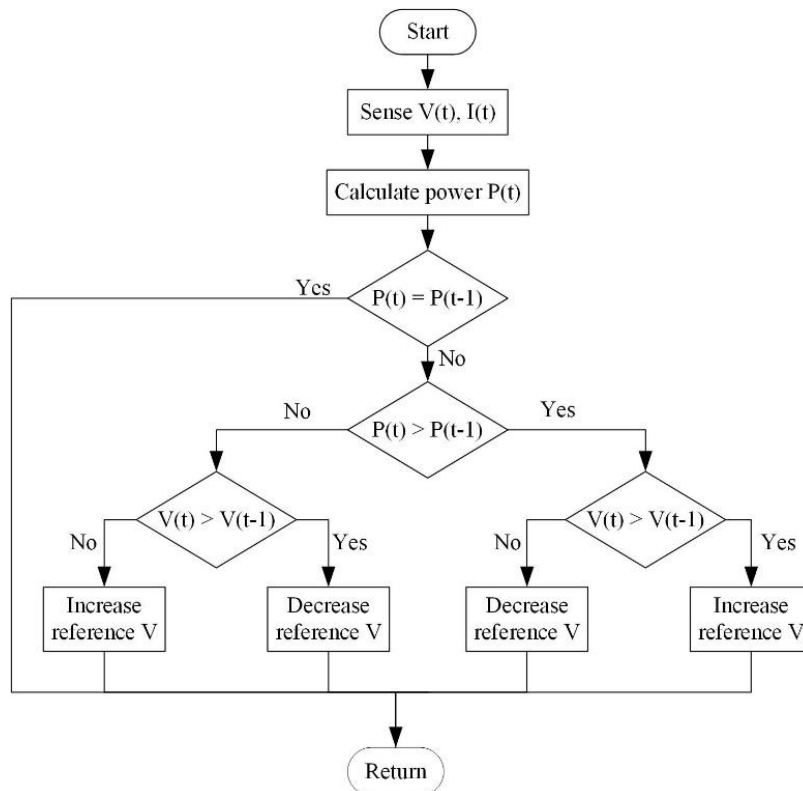

Figure 4. Flowchart of P&O algorithm.

### 3. RESULTS AND DISCUSSION

The tracking performance of the both algorithms under real-time simulation platform were examined using the HIL Supervisory Control and Data Acquisition (SCADA) and a Keysight Mixed Signal Oscilloscope MSOX-2024A. The tracking performance of the two MPPT algorithms in study were examined using 10 different partially shaded test cases as shown in Figure 5. The staircase-like  $I$ - $V$  characteristic curves shown in Figure 5 were the results of the entire series connected PV string does not receive equal amount of irradiance.

In overall, it can be seen obviously that the P&O can track for maximum power operating point faster than PSO. In term of tracking output efficiency, PSO was able to track for maximum power point more effective than P&O under partially shaded conditions. The output efficiency and the convergence time of the tracking for both algorithms in study are summarised in Table 1. The output efficiency of the tracking was obtained based on the output power from the tracked operating point of the PV system compared to the theoretical maximum power obtained. The theoretical maximum power stated is the maximum output power available from the PV system under the particular shaded condition, and it is obtained through the sweeping of the operating point of the PV system from open circuit voltage ( $V_{oc}$ ) to short circuit current ( $I_{sc}$ ).

The main objective of a MPPT controller is to locate the maximum power operating point for a PV system. Due to this, the ability of the MPPT controller to track for the correct maximum power operating point in order for the PV system to maximize its output power is prime important. From the experiment, the PSO was able to achieve the average output efficiency up to 99.92% while P&O was only able to achieve up to average of 76.76%. This is because when the PV system is under partially shaded condition, the  $P$ - $V$  characteristic curve exhibits in multiple peaks scenario with only one true peak. Under such condition, the hill climbing behavior of P&O will cause the tracking to be trapped at local maxima where the algorithm assume the maximum power point is located. However, under the situation where the maximum power operating point was coincidentally near the point where the duty cycle was initiated, the P&O was able to locate the operating point effectively.

Unlike P&O, the search particles of PSO were scattered in the search space to locate the maximum power operating point randomly. The algorithm will compare the solution from the search particles and update the successive position of the particles accordingly. This brought to the potential for the algorithm to locate for the true maximum power operating point due to the exploration of the search particles in the search space to look for a better solution. Through the exploration and position updates, the search particles will eventually converge towards a point where the system is able to generate maximum power.

In MPPT application, the convergence time of the tracking algorithm plays an important role to ensure that the PV system can reach its maximum power operating point in shortest time, hence to minimise the power losses. In this study, the convergence time was taken as time taken for the algorithm from the beginning of the tracking operation until it reaches 98% of the tracked output power. In this case, it is important that the time taken for the cases in P&O which were trapped at local maxima does not reflect the actual performance of the algorithm. From the results shown in Table 1, the convergence time of P&O ranges from 0.5070 s to 0.9612 s without consider the case which it was trapped at local maxima. While for PSO, the tracking time is slower than P&O which it ranges from 1.3598 s to 2.1248 s.

From the tracking performance, it is very obvious that the conventional P&O methods can track for MPPT faster than PSO under real-time situation. This is because the conventional P&O method only require the comparison of its present output value with its stored value from previous perturbation. While for PSO method, the tracking was slower due to the complex computation of the movement of search particles. The real-time data obtained from oscilloscope under test case 8 for the tracking of P&O and PSO are shown in Figure 6 and Figure 7 respectively. From the tracking, it can be seen that when the tracking process started, the P&O climbed towards the maximum power point in a smooth steps. The system fluctuates during the tracking process of PSO was due to the sequential sampling of the output power corresponding with different particle positions. It can also be seen from Figure 6 that the P&O initiated its tracking process near the  $V_{oc}$ , hence the algorithm was able to track for the maximum power point effectively for the cases where its true maximum power operating point was near the  $V_{oc}$ .

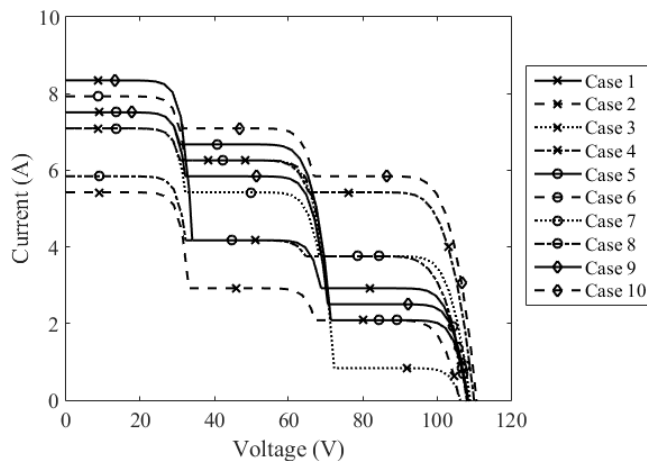

Figure 5.  $I$ - $V$  characteristic curve of ten different partially shaded test cases.

Table 1. The real-time tracking performance of P&O and PSO under partial shaded conditions

Case	Shading Pattern (1 = 1000 W/m <sup>2</sup> )			Theoretical Maximum Power (W)	Output Efficiency (%)		Convergence Time (s)	
	A	B	C		P&O	PSO	P&O	PSO
1	1.00	0.50	0.35	278.2	99.50	99.75	0.6498	2.0856
2	0.65	0.35	0.25	194.1	99.69	99.95	0.5070	1.6688
3	0.90	0.75	0.10	377.2	21.26*	99.97	0.1956*	1.3658
4	0.85	0.75	0.65	505.4	99.54	99.94	0.9264	1.3598
5	0.90	0.80	0.25	398.9	50.61*	99.97	0.5760*	1.5718
6	0.95	0.75	0.25	380.6	53.05*	99.84	0.4961*	1.4700
7	0.85	0.65	0.45	357.5	99.52	99.94	0.7763	2.1248
8	0.70	0.50	0.45	345.3	99.57	99.94	0.7612	1.8800
9	0.90	0.70	0.30	354.3	45.47*	99.92	0.4208*	1.3660
10	1.00	0.85	0.70	552.9	99.40	99.95	0.9612	1.9792
Average					76.76	99.92	0.6270	1.6872

\*algorithm trapped at local maxima

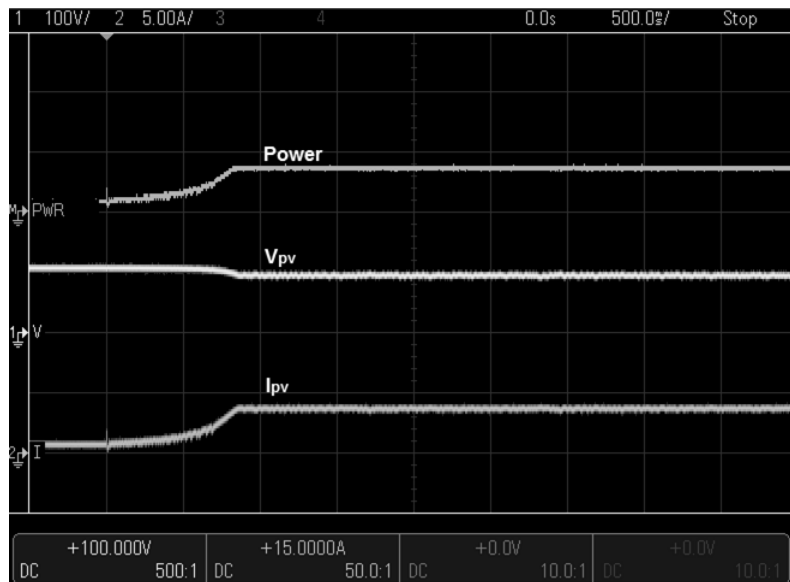

Figure 6. The tracking process of P&O captured in oscilloscope for test case 8

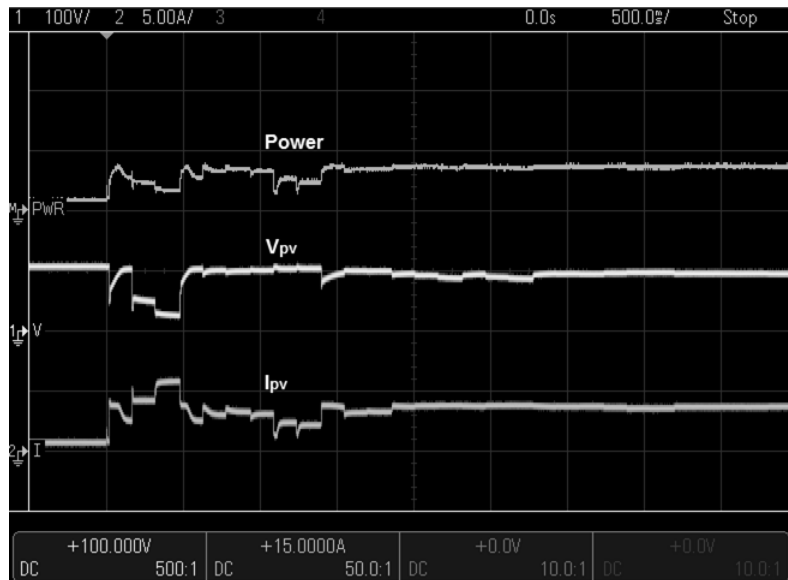

Figure 7. The tracking process of PSO captured in oscilloscope for test case 8

#### 4. CONCLUSION

From this study, the real-time performance of two MPPT algorithms; P&O and PSO were successfully investigated using Typhoon HIL-402. The modelling and application of the PV system and power electronic converter in HIL device reduces the prototyping time and eliminates the potential hazards during the testing. Despite P&O can converge towards the maximum power operating point faster than PSO, it can only achieve the average tracking output efficiency up to 76.76%. On the other hand, PSO has shown a better tracking output efficiency which is up to 99.92% although it takes longer time to converge to its maximum power operating point. The study also shows the capability of the implementation of the PSO-based MPPT algorithm into the real world MPPT application, which it gives a promising output for the partially shaded PV system.

#### ACKNOWLEDGMENT

The authors would like to thank Faculty of Electrical and Electronics Engineering, Universiti Malaysia Pahang for the support of this research under research grant RDU1703129.

#### REFERENCES

- [1] K. Ishaque and Z. Salam, A review of maximum power point tracking techniques of PV system for uniform insolation and partial shading condition, *Renewable and Sustainable Energy Review*, 19, 475–488, 2013.
- [2] O. Singh and S. K. Gupta, A review on recent MPPT techniques for photovoltaic system, *Proceedings of 2018 IEEMA Engineer Infinite Conference (eTechNxT)*, Delhi, 2018, pp. 1–6.
- [3] A. Mohapatra, B. Nayak, P. Das and K. B. Mohanty, A review on MPPT techniques of PV system under partial shading condition, *Renewable and Sustainable Energy Review*, 80, 854–867, 2017.
- [4] M. A. M. Ramli, S. Twaha, K. Ishaque and Y. A. Al-Turki, A review on maximum power point tracking for photovoltaic systems with and without shading conditions, *Renewable and Sustainable Energy Review*, 67, 144–159, 2017.
- [5] S. Amin, S. Khan and A. Qayoom, Comparative analysis about the study of maximum power point tracking algorithms : A Review, *Proceedings of 2018 IEEE International Conference on Computing, Mathematics and Engineering Technologies (iCoMET)*, Sukkur, 2018, pp. 1–8.
- [6] M. A. Ghasemi, H. M. Forushani and M. Parniani, Partial shading detection and smooth maximum power point tracking of PV arrays under PSC, *IEEE Transactions on Power Electronics*, 31(9), 6281–6292, 2016.
- [7] M. C. Tiong, H. Daniyal, M. H. Sulaiman and M. S. Bakar, Binary search algorithm as maximum power point tracking technique for photovoltaic system under partial shaded conditions, *Proceedings of 3rd IEEE Conference on Energy Conversion (CENCON)*, Kuala Lumpur, 2017, pp. 10–14.
- [8] T. Sudhakar Babu, N. Rajasekar and K. Sangeetha, Modified Particle Swarm Optimization technique based maximum power point tracking for uniform and under partial shading condition, *Applied Soft Computing Journal*, 34, 613–624, 2015.
- [9] Z. Salam, J. Ahmed and B. S. Merugu, The application of soft computing methods for MPPT of PV system: A technological and status review, *Applied Energy*, 107, 135–148, 2013.
- [10] S. Motahhir, A. El Ghzizal, S. Sebti and A. Derouich, MIL and SIL and PIL tests for MPPT algorithm, *Cogent Engineering*, 4(1), 1–18, 2017.
- [11] J. Nibert, M. E. Herniter and Z. Chambers, Model-based system design for MIL, SIL, and HIL, *World Electric Vehicle Journal*, 5, 1121–1130, 2012.

- [12] M. Steurer, F. Bogdan, W. Ren, M. Sloderbeck and S. Woodruff, Controller and power hardware-in-loop methods for accelerating renewable energy integration, *Proceedings of 2007 IEEE Power Engineering Society General Meeting*, Tampa, FL, 2007, pp. 5–8.
- [13] S. J. Chiang, H. -J. Shieh and M. -C. Chen, Modeling and control of PV charger system with SEPIC converter, *IEEE Transactions on Industrial Electronics*, 56(11), 4344–4353, 2009.
- [14] G. Walker, Evaluating MPPT converter topologies using a MATLAB PV model, *Journal of Electrical and Electronics Engineering Australia*, 21(1), 49, 2001.
- [15] K. Ishaque, Z. Salam, A. Shamsudin and M. Amjad, A direct control based maximum power point tracking method for photovoltaic system under partial shading conditions using particle swarm optimization algorithm, *Applied Energy*, 1(99), 414–422, 2012.
- [16] J. P. Ram, T. S. Babu and N. Rajasekar, A comprehensive review on solar PV maximum power point tracking techniques, *Renewable and Sustainable Energy Review*, 67, 826–847, 2017.
- [17] A. Reza Reisi, M. Hassan Moradi and S. Jamasb, Classification and comparison of maximum power point tracking techniques for photovoltaic system: A review, *Renewable Sustainable Energy Review*, 19, 433–443, 2013.
- [18] K. Sundareswaran and S. Palani, Application of a combined particle swarm optimization and perturb and observe method for MPPT in PV systems under partial shading conditions, *Renewable Energy*, 75, 308–317, 2015.
- [19] M. Miyatake, F. Toriumi, T. Endo and N. Fujii, A novel maximum power point tracker controlling several converters connected to photovoltaic arrays with particle swarm optimization technique, *Proceedings of 12th European Conference on Power Electronics and Applications*, Aalborg, 2007, pp. 1-8.
- [20] M. Miyatake, M. Veerachary, F. Toriumi, N. Fujii and H. Ko, Maximum power point tracking of multiple photovoltaic arrays: a PSO approach, *IEEE Transactions on Aerospace Electronic Systems*, 47(1), 367–380, 2011.
- [21] K. Ishaque, Z. Salam, M. Amjad and S. Mekhilef, An improved Particle Swarm Optimization (PSO)-based MPPT for PV with reduced steady-state oscillation, *IEEE Transactions on Power Electronics*, 27(8), 3627–3638, 2012.